

Multi-Function Safety System SAFEMASTER M Input Module BG 5914.08/_ 0 ___, BH 5914.08/_ 0 __-

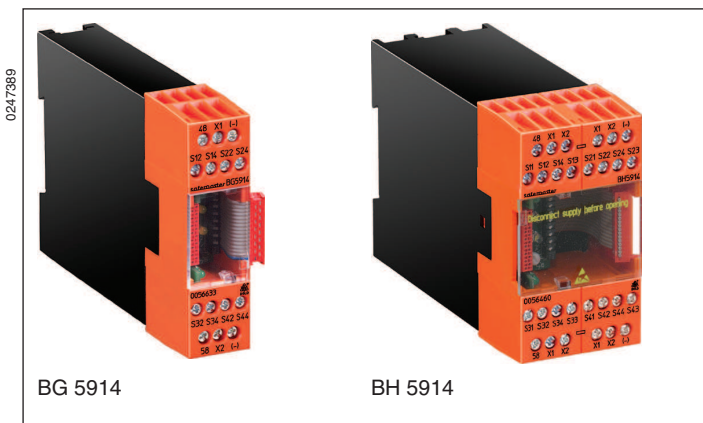

0247389

- According to
 - Performance Level (PL) d and category 2 to EN ISO 13849-1: 2008
 - SIL Claimed Level (SIL CL) 2 to IEC/EN 62061
 - Safety Integrity Level (SIL 2) to IEC/EN 61508
- Input module for realization of:
 - 8 E-STOP, single-channel, autostart
 - 6 E-STOP, single-channel, + 1 E-STOP, 2-channel, autostart
 - 5 E-STOP, single-channel, + 1 -STOP, 2-channel + 1 signal input, autostart
 - 8 E-STOP, single-channel, manual start
 - 6 E-STOP, single-channel, + 1 E-STOP, 2-channel, manual start
 - 5 E-STOP, single-channel, + 1 E-STOP, 2-channel + 1 signal input, manual start
 - As an alternative to the 2-channel E-STOP, a light curtain (LC type 4) according to EN 61496-1 can be connected.
- Broken wire and short circuit monitoring function with error indication
- 2 semiconductor outputs per function module for status indication
- LEDs for status indication
- Width: 22.5 mm (BG 5914) or 45 mm (BH 5914)

Block Diagrams

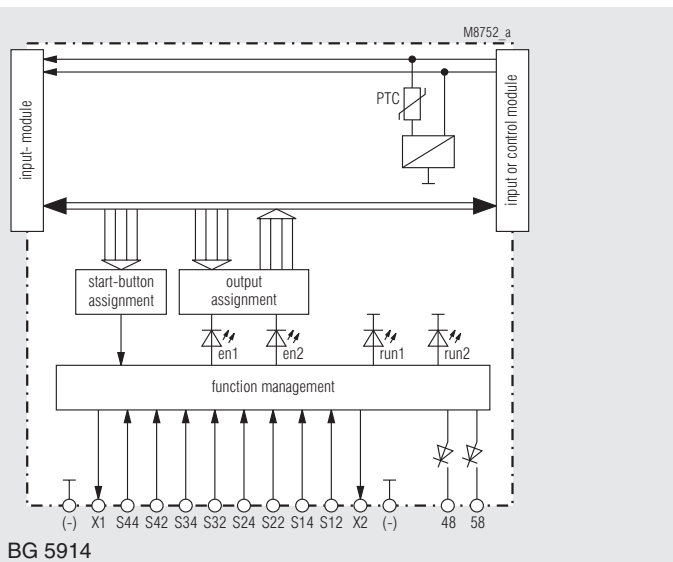

BG 5914

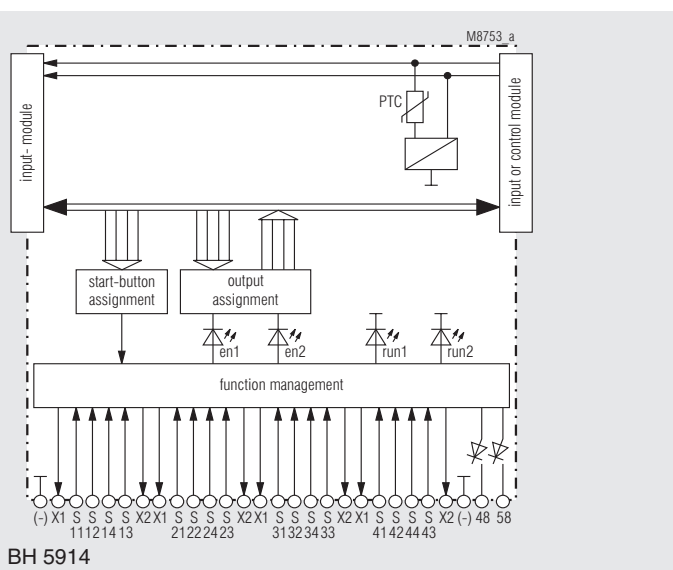

BH 5914

Approvals and Markings



Applications

Realization of fail-safe control circuits for protection of people and machinery. The modules BG 5914 and BH 5914 have been developed for applications in which numerous one-channel Emergency stop contacts have to be monitored.

Circuit Diagrams

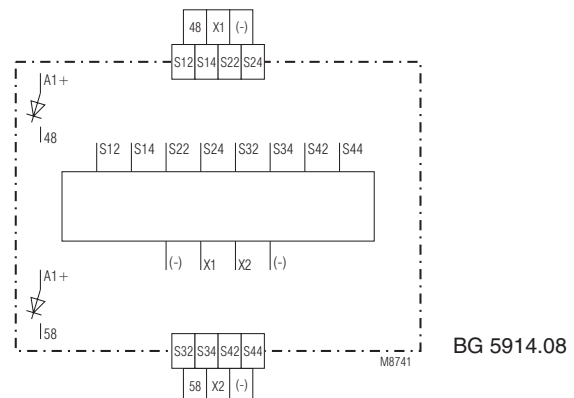

BG 5914.08

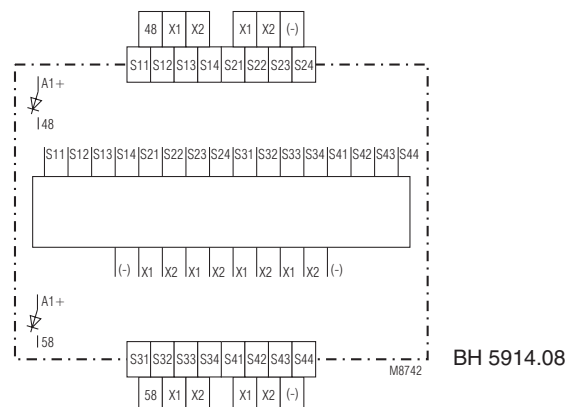

BH 5914.08

General Information SAFEMASTER M

The maximum configuration of the SAFEMASTER M multi-function safety system is as follows:

- the control unit BH 5911
- up to 3 input modules BG/BH 5913, or BG/BH 5914, BG/BH 5915
- up to 3 output modules BG 5912
- 1 diagnostic module BG 5551 for CANopen, or
- 1 diagnostic module BG 5552 for Profibus-DP

The BH 5911 controls the whole system.

The input/output modules can be used to expand the control unit in a modular way into a multi-functional safety system.

To transmit status messages of the individual modules to a monitoring or control unit, one of the following diagnostic modules may be connected:

- BG 5551 for CANopen
- BH 5552 for Profibus-DP

Notes

In respect of function and settings, the modules BG 5914 and BH 5914 are completely identical.

- The modules BG 5914 have 8 inputs with one common ground. This is the ground of the overall system. They are suitable for all applications in which volt free contacts are used, or where there is a common ground (e.g. 2-channel light curtains). They need only 8 terminals and thus only have an overall width of 22.5 mm.
- The modules BH 5914 have 8 completely DC-decoupled inputs. In the settings for a 2-channel Emergency stop, several systems can be operated from the same E-stop button.
- The modules BH 5914 **must** be used as soon as one Emergency stop contact is executed on several modules. Here, short-circuit monitoring is effected by a certain type of wiring according to the application examples.

Indication

Green LEDs: on, when all inputs are present and start button activated.

White LEDs Run 1/ Run 2 and outputs 48 and 58: indicate the current status of the module.

Signal Input

This input does not have a safety function. It is used only to signal the status of a switch (NO contact) and does not affect the safety outputs assigned to the module (e.g. when the machine is set to service mode).

- If voltage is applied to the input, the white LED Run 2 is ON. The semiconductor output 58 is OFF as long as no Emergency stop is active.
- If no voltage is applied to the input, the white LED Run 2 will go out, and the semiconductor output 58 will become conductive.

Setting of the Module

In respect of function and settings, the modules BG 5914 and BH 5914 are completely identical.

The modules are assigned to the start buttons and the safety outputs via the DIP switches.

The function is set via the rotary switches. To prevent accidentally adjustments, these elements are covered by a front plate and are redundant.

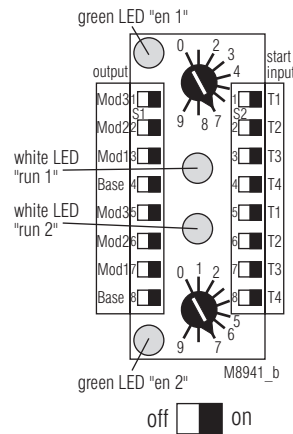
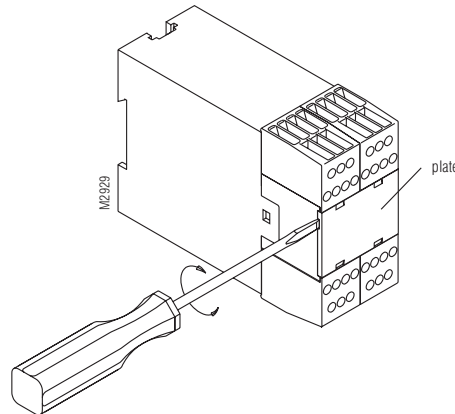

Note:

- Settings to the unit must be performed by skilled personnel while the unit is off-load.
- Before the front cover is removed, potential equalization must be provided.

Sw.	Function
0	8 Emergency stop single-channel, autostart
1	6 emergency stop, single-channel, + 1 emergency stop, 2-channel with short circuit detection, autostart
2	6 emergency stop, single-channel, + 1 emergency stop, 2-channel without short circuit detection or 1 LC type 4, autostart
3	5 emergency stop, single-channel, + 1 emergency stop, 2-channel without short circuit detection or 1 LC type 4 + 1 signal input, autostart
4	8 Emergency stop single-channel, manual start
5	6 emergency stop, single-channel, + 1 emergency stop, 2-channel with short circuit detection, autostart
6	6 emergency stop, single-channel, + 1 emergency stop, 2-channel without short circuit detection or 1 LC type 4, manual start
7	5 emergency stop, single-channel, + 1 emergency stop, 2-channel without short circuit detection or 1 LC type 4 + 1 signal input, manual start
8, 9	8, 9 not assigned (error 5)

Setting of the Module

Note:

This module is intended for applications in which numerous one-channel Emergency off contacts are to be monitored.

The settings 2, 3, 6, and 7 are required for example when several modules are connected to a common Emergency stop sensor. Short-circuit recognition can be realized externally by means of proper wiring.

With a LC type 4 (according to IEC/EN 61496-1), short-circuit monitoring takes place in the light curtain itself.

Single-Channel Emergency-Stop

With single-channel safety inputs, safety function can only be realized when voltfree contacts are used (see wiring examples).

With static, voltage signals, it is imperative to use 2-channel signal sensors.

Automatic Start

Automatic start is performed only when supply voltage is switched on, or when enabling has been cancelled by pressing Emergency stop.

All other errors nevertheless require confirmation by a start key.

Manual Start

To start the system, do not keep the start key pressed for more than 3 seconds. A module may also be assigned several start keys.

Indication of System Errors

These errors are indicated by flashing codes of the white LEDs Run 1 and/or Run 2. The green LEDs and all outputs turn inactive. The system will only restart after the supply voltage has been switched off and on again.

Error codes*

- 0) (both white LEDs are off):
Another input module indicates a system error.
- 1) To 4): not used
- 5) Incorrect setting of function:
 - The rotary switches for channel 1 and 2 has different or incorrect positions
 - The setting of the 4 upper Dip-switches (channel 1) are not identically to the 4 lower Dip-switches (channel 2)
- 6) LED Run 1 flashes: Undervoltage
LED Run 2 flashes: Overvoltage
- 7), 8) Not used
- 9) Connection error between the input modules
No terminating connector available.
 - Control or input module defective
- 10), 11), 12), 13) a. 14) Internal errors

* number of short flashing impulses, followed by a longer space

Indication

	Permanently OFF	Pulsing	Permanent ON
Output 48	all relays inactive due to system error	one input function not available	Activation of the assigned safety outputs is permissible
LED Run 1	all relays inactive due to system error	one input function not available (LED run 2 ON) or system error when LED Run 2 is OFF or flashing	Activation of the assigned safety outputs is permissible
Output 58	Activation of the assigned safety outputs is permissible or system error	Wait for start	one input function not available or K1 and K2 active and indicator contact inactive
LED Run 2	all relays inactive due to system error or K1 and K2 active and indicator contact inactive	all relays inactive due to system error	No system error

Indication of Function Errors

Function errors are indicated by the white LED Run 1 and by output 48; the white LED Run 2 remains on. Output 58 remains on as long as the error is pending; it flashes regularly as soon as enabling via the assigned start button is possible again:

Error codes*

- 1) Emergency stop
- 2) Time error: Start button has been kept pressed for more than 3 seconds
- 3) Time error: The 2 signals of the 2-channel Emergency stop fail to correspond for too long (250 ms)
- 4) Error on start button (kept permanently pressed)
- 5) Input error (short-circuit, interruption)
- 6) Error in the control unit (input or output error recognized in the control unit)

* number of short flashing impulses, followed by a longer space

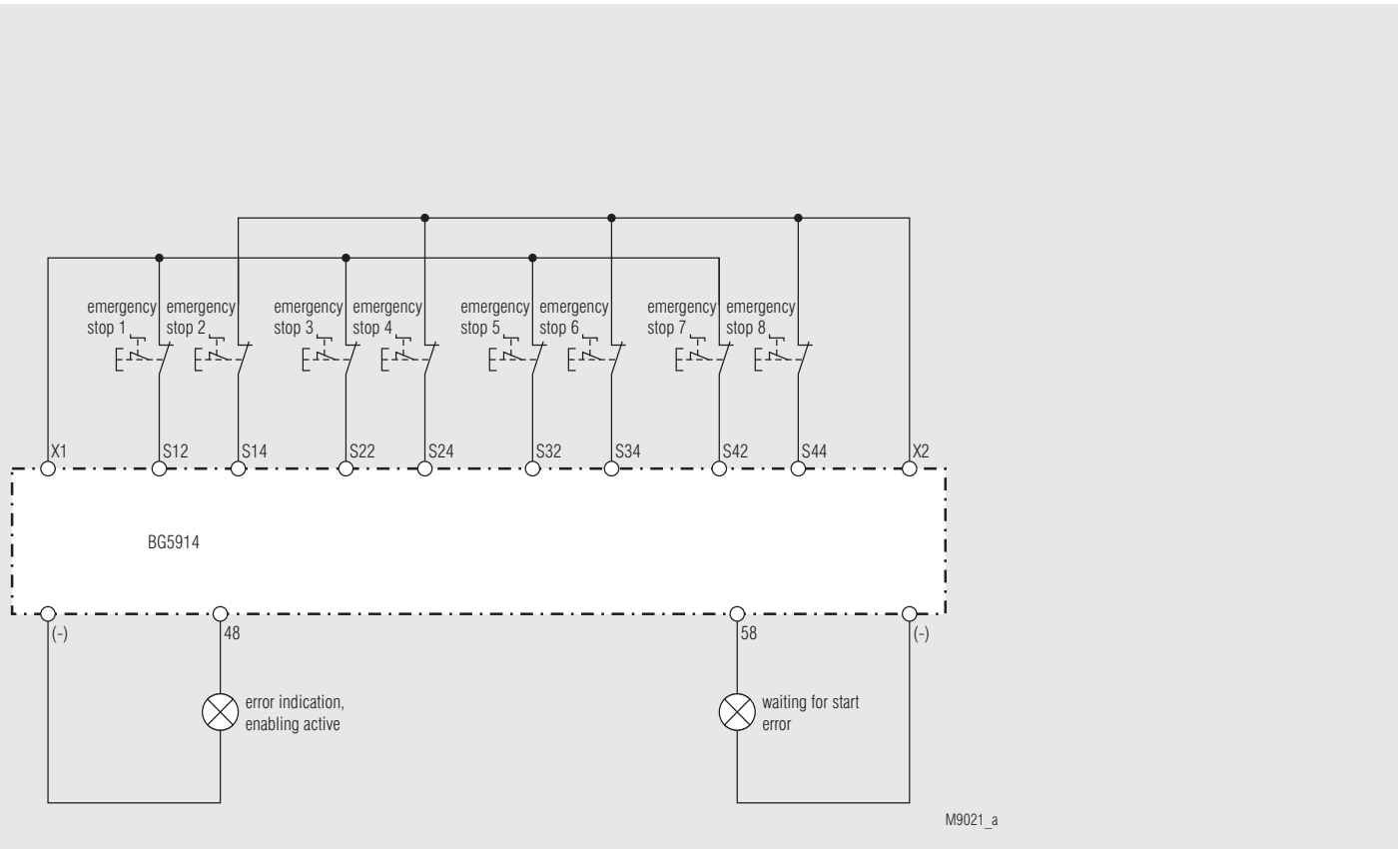

M9021_a

BG 5914, 8 Emergency stop, single-channel, voltage-free contacts; functions: 0 or 4

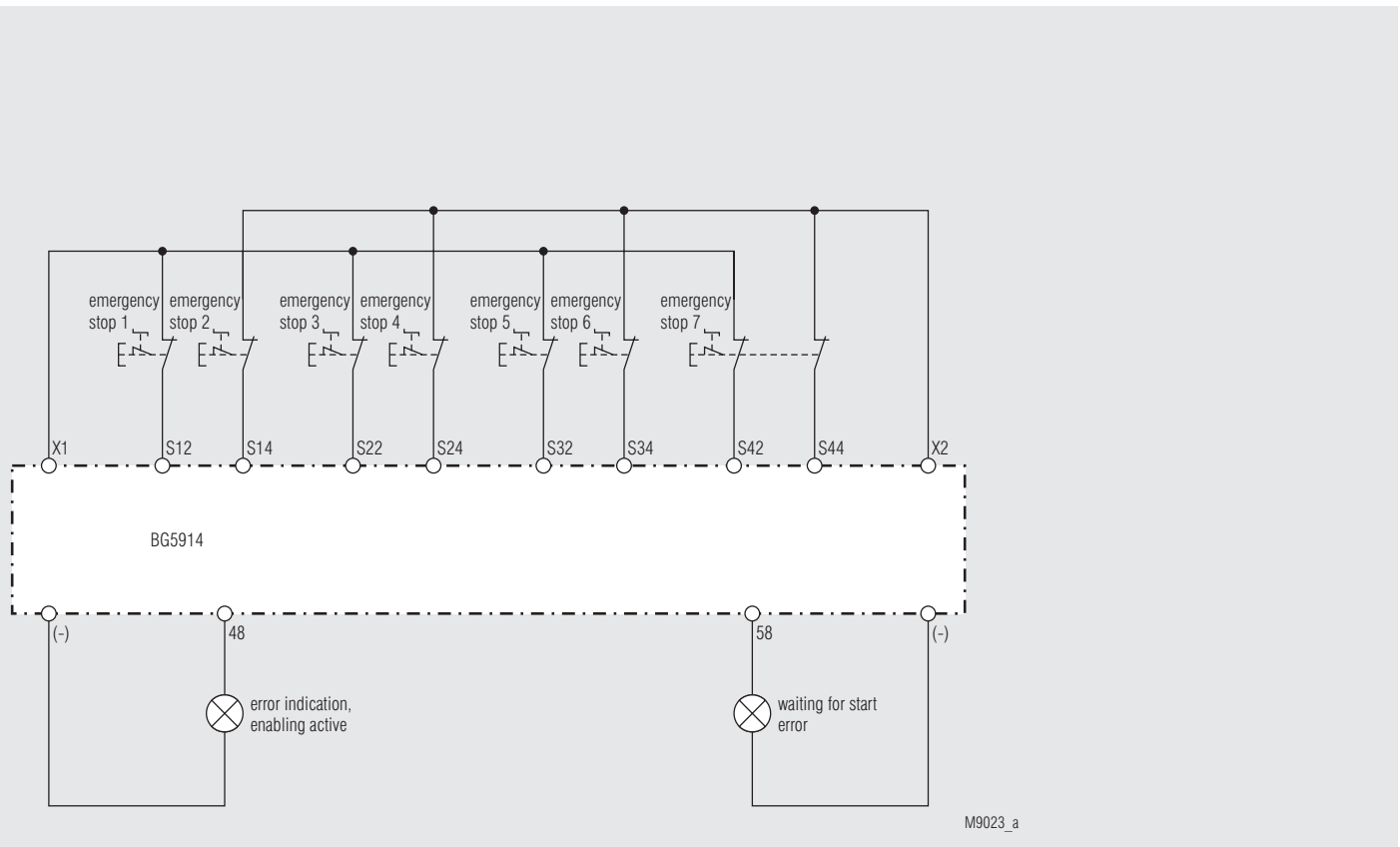

M9023_a

BG 5914, 6 Emergency stop single-channel, + 1 Emergency stop, 2-channel with short-circuit detection; functions: 1 or 5

Application Examples

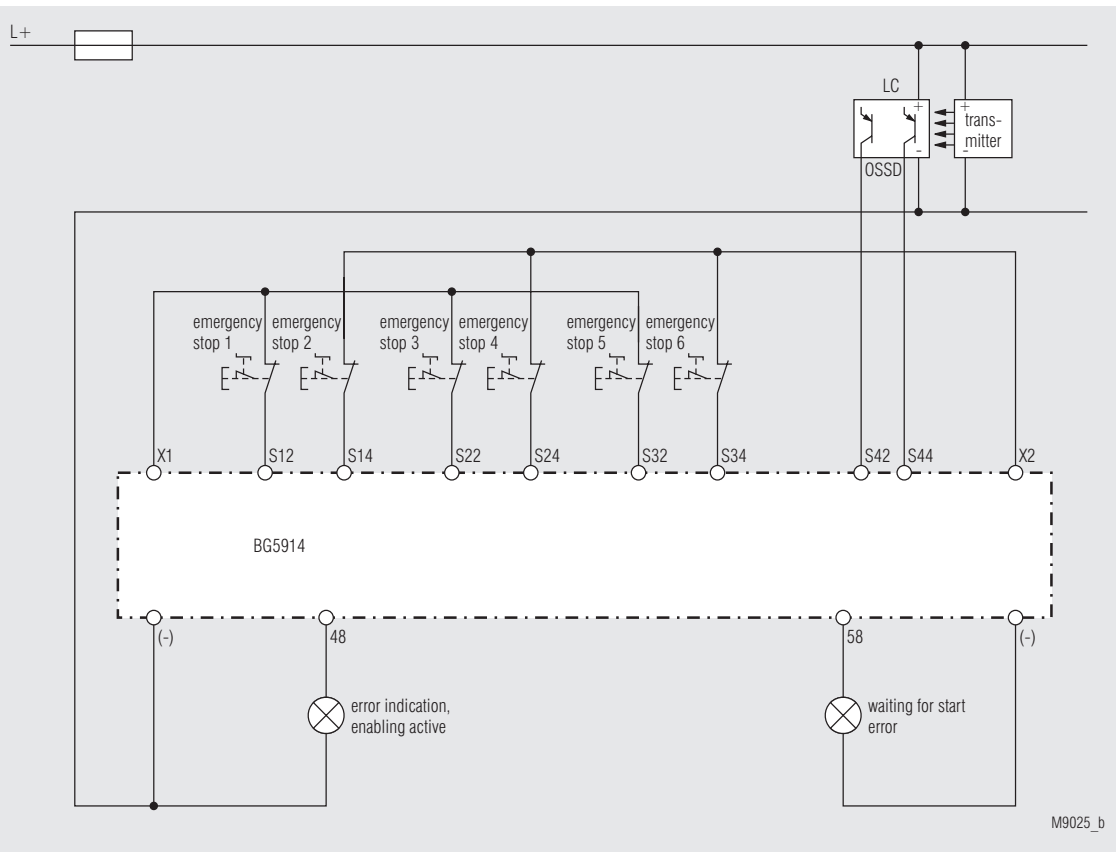

BG 5914, 6 Emergency stop single-channel + 1 light curtain type 4; functions 2 or 6

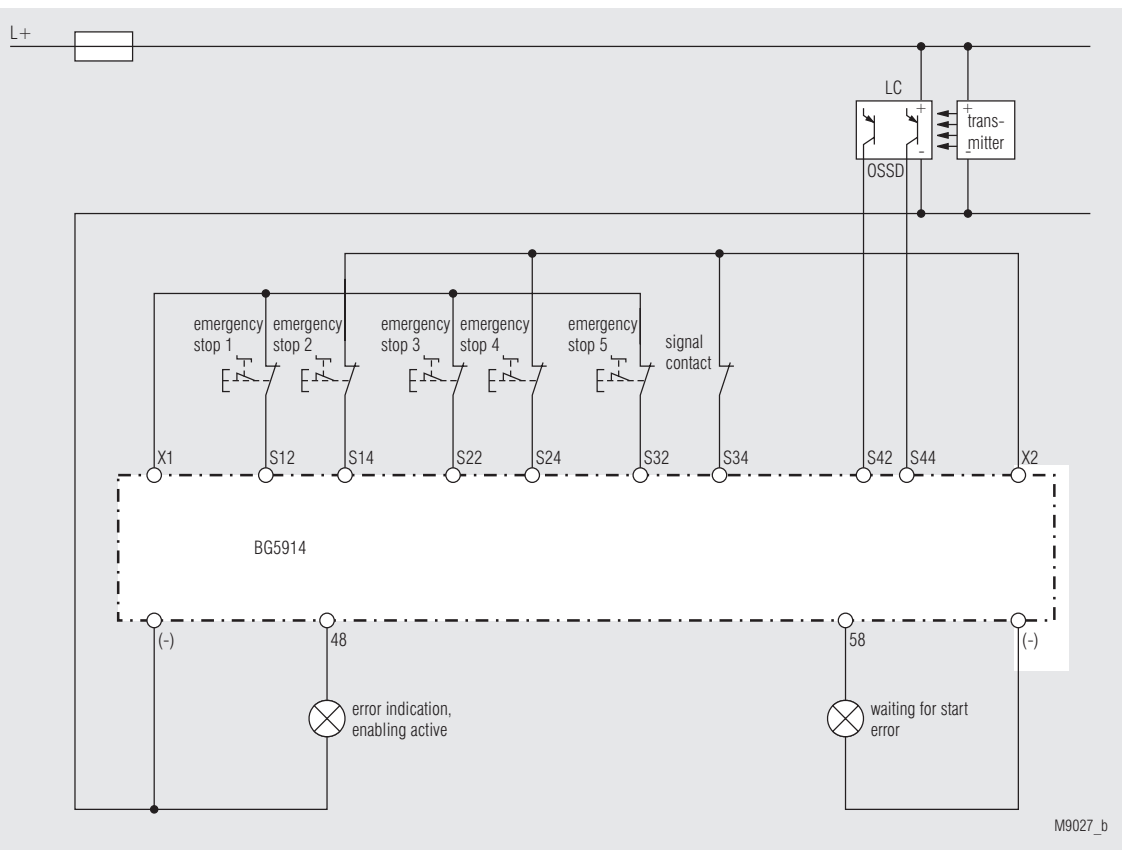

BG 5914, 5 Emergency stop single-channel + 1 light curtain type 4 + 1 signal contact; functions 3 or 7

Application Examples

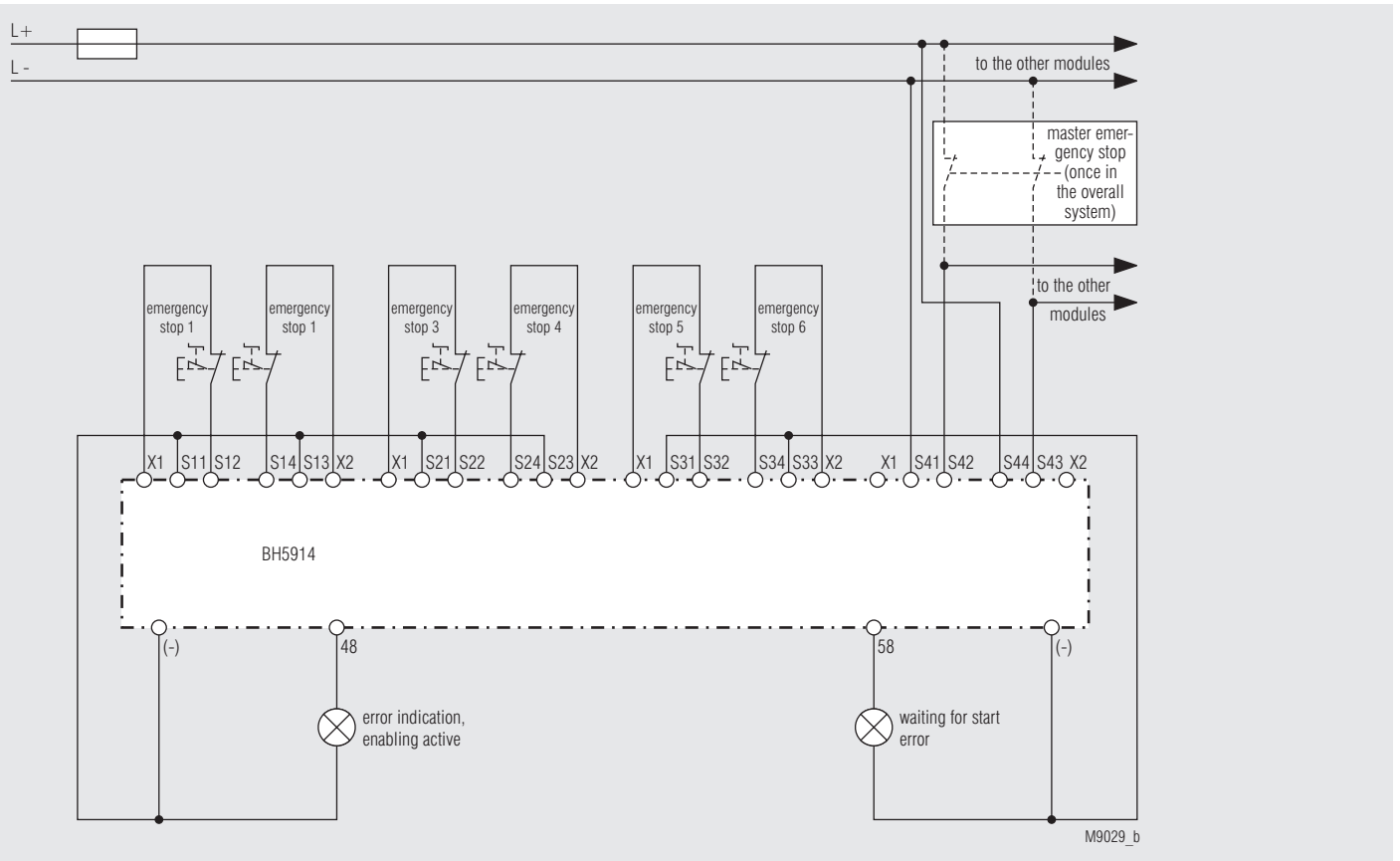

BH 5914, 6 Emergency stop single-channel + 1 Master Emergency stop 2-channel with short-circuit detection by means of wiring; functions: 2 or 6

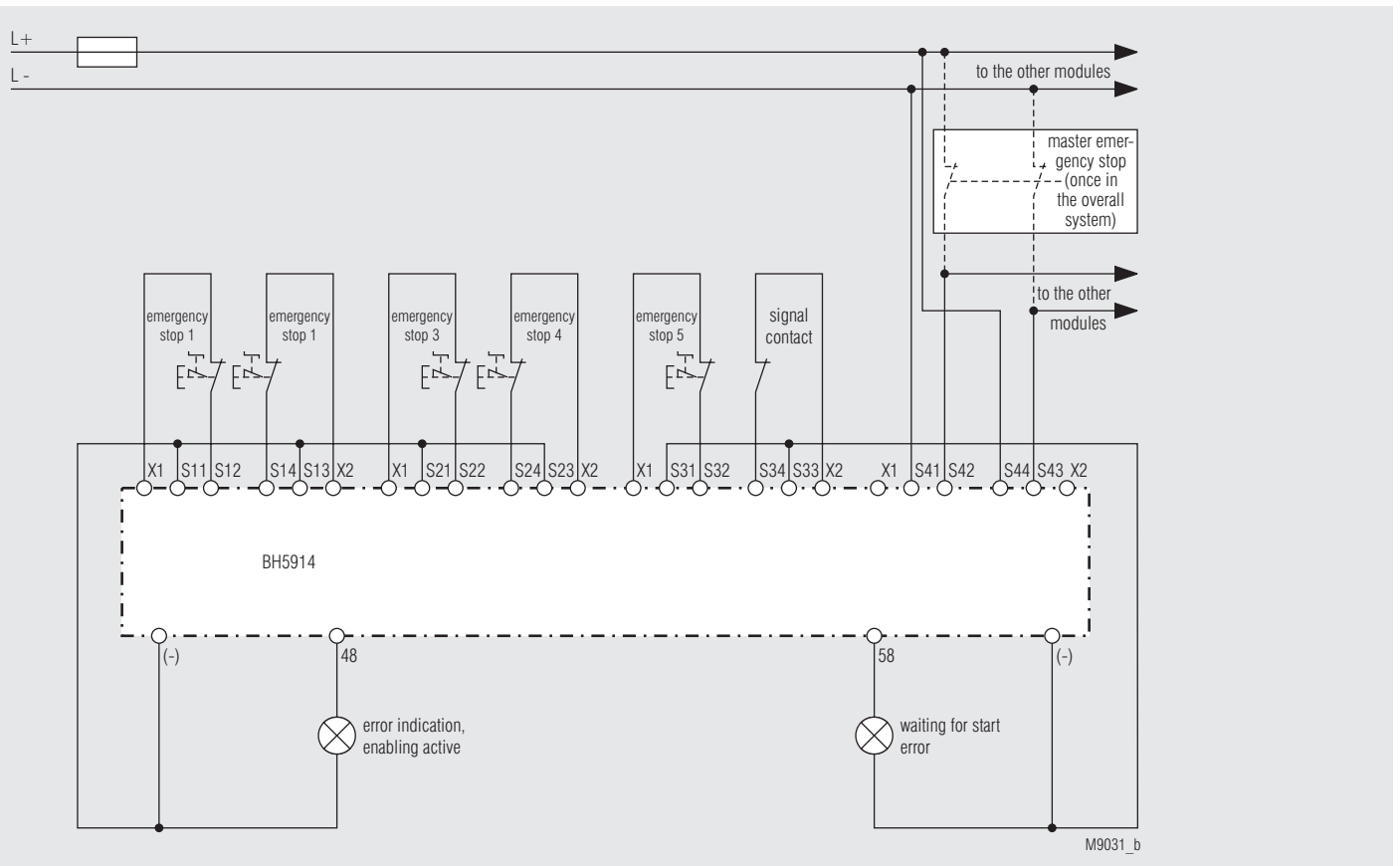

BH 5914, 5 Emergency stop single-channel + 1 Master Emergency stop 2-channel with short-circuit detection by means of wiring + 1 signal contact; functions 3 or 7

Technical Data	
Voltage Supply	
Nominal voltage U_N:	DC 24 V (comes from basic module BH 5911)
Voltage range: with max. 5% residual ripple:	0.85 ... 1.15 U_N
Nominal consumption:	max. 60 mA (no load on semiconductor outputs)
Short-circuit protection of the modules:	internally with PTC
Inputs:	
Control voltage over X1, X2, X42, 48, 58:	DC 23 V at U_N
Control current over S11, S12, S13, S14, S21, S22, S23, S24, S31, S32, S33, S34, S41, S42, S43 S44:	4.5 mA each at U_N
Minimum voltage at S12, S14, S22, S24, S32, S34 S42, S44	DC 16 V

Outputs

Output on terminal 48 and 58:	Transistor outputs, plus-connected
Output nominal voltage:	DC 24 V, max. 100 mA constant current, max. 400 mA for 0.5 s Internal overtemperature and overload protection

Reaction Times (time till reaction of the assigned output):

Typ. operating time with U_N :

Input modules BG 5914 and BH 5914	Manual start	Automatic start	
		First start	Restart
Emergency stop	max. 75 ms	max. 1 s	max. 75 ms

Break time (reaction time):

Input modules BG 5914 and BH 5914	
Emergency stop	max. 33 ms

General Data

Operating mode:	Continuous operation
Temperature range:	$\pm 0 \dots + 50 \text{ }^\circ\text{C}$ At an operating temperature of $50 \text{ }^\circ\text{C}$ the modules must be mounted with a distance of 3 - 5 mm.

Clearance and creepage
distances

rated impulse voltage /
pollution degree: 4 kV / 2 (basis insulation) IEC 60 664-1

EMC: IEC/EN 61 326-3-1, IEC/EN 62 061
Radio interference suppression: Limit value class A EN 55011

Remark: This device is designed for industrial ambient conditions.
When used in other environment, it is possible that wire bound or
radiated interference occurs.

Degree of protection

Housing:	IP 20	IEC/EN 60 529
Terminals:	IP 20	IEC/EN 60 529

Housing: Thermoplast with V0 behavior
according to UL Subject 94

Vibration resistance: Amplitude 0.35 mm

Shock resistance

Acceleration:	10 g
Pulse duration:	16 ms

Technical Data	
Number of shocks:	1000 per axis on three axes
Climate resistance:	0 / 050/ 04 IEC/EN 60 068-1
Terminal designation:	EN 50 005
Wire connection:	1 x 2.5 mm ² stranded wire with sleeve, or 1 x 4 mm ² massive or 2 x 1.5 mm ² litz with sleeve DIN 46 228-1/-2/-3/-4
Wire fixing:	Box terminal with wire protection, remov- able terminal strips
Mounting:	DIN rail IEC/EN 60715
Dimensions	

Width x height x depth:

BG 5914:	22.5 x 84 x 121 mm
BH 5914:	45 x 84 x 121 mm

Safety Related Data for E-STOP

Values according to EN ISO 13849-1:

Category:	2	
PL:	d	
MTTF _d :	1207,5	a (year)
DC _{avg} :	92,7	%
d _{op} :	365	d/a (days/year)
h _{op} :	24	h/d (hours/day)
t _{zyklus} :	3600	s/Zyklus
	≅ 1	/h (hour)

Values according to IEC EN 62061 / IEC EN 61508:

SIL CL:	2	IEC EN 62061
SIL	2	IEC EN 61508
HFT ^{*)} :	0	
DC _{avg} :	92,7	%
SFF:	99,0	%
PFH _D :	3,53E-09	h ⁻¹

^{*)} HFT = Hardware-Failure Tolerance



The values stated above are valid for the standard type.
Safety data for other variants are available on request.

The safety relevant data of the complete system has to be
determined by the manufacturer of the system.

Purchase Order Numbers Input Module E-Stop

BG 5914.08/00MF0:	8 floating inputs (width 22.5 mm)
Article Number:	0056633
BH 5914.08/00MF0:	8 floating or non-floating inputs (width 45 mm)
Article Number:	0056460

